

CLOUD

Condensation nebulizer

Into the box



System for nebulizing condensates from air conditioning mm 200 x 154 x 85



Nebulizer nozzle made of steel
Anti-corrosion stainless



Connecting pipe
Ø 6 mm



Cable tie for the adaptor



Max 8 kW
Sound level 35 dBA

CLOUD is a system for nebulizing condensate drains from air conditioning systems, to be installed when condensate drainage problems occur. CLOUD provides a savings in installation costs, as it does not require condensate discharge piping.

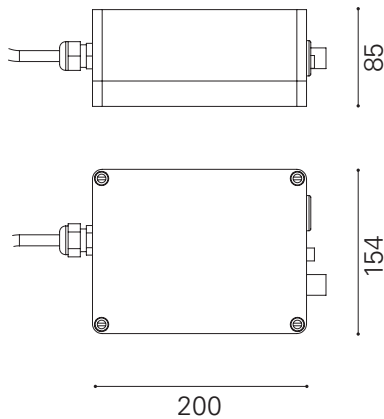

Code	Article	Description
SP0477222	CLOUD	CLOUD condensation nebulizer

Technical data

- Max flow.....5 l/h
- Max head.....19 bar
- Voltage.....230V - 50Hz
- Max absorption.....50 W
- Inlet filter.....yes
- Protection class.....IP44
- Max temperature condensate.....40°C
- PH condensate.....6÷8
- Power cable / Schuko.....2 m
- Inlet pipe.....Ø max 15 mm
- Outlet pipe.....Ø 6 mm
- Certification.....CE
- RoHS 2 compliantApproved

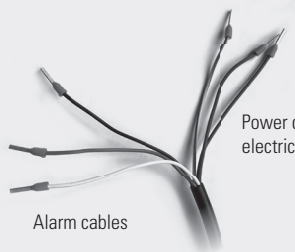

Power cables
electric

Alarm cables

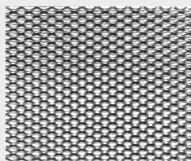

Pump suction filter

- Connect to each single and multi split air conditioner
- Use for indoor and outdoor drains
- Nozzle can be attached anywhere on the wall or outdoor unit

